

Description

- Medium time delay, low breaking capacity
- 5mm x 20mm physical size
- Glass tube, nickel-plated brass endcap construction
- Optional axial leads are .032" x 1.5" copper tinned
- Optional sleeve is flexible flouropolymer (U.L. flammability rating VW-1)
- Designed to UL/CSA 248-14



ELECTRICAL CHARACTERISTICS		
Rated Current	% of Amp Rating	Opening Time
63mA - 10A	100%	None
	135%	60 minutes maximum
	200%	2 minutes maximum

Approvals

- UL Listed, Guide JDYX, File E75865, 63mA-6.3A
- UL Recognition, Guide JDYX2, File E75865, 7A-8A
- CSA Certified, Class 1422-01, File E65063, 63mA-6.3A

Ordering

- Specify product code, option code and packaging code

Dimensions mm/(inches)

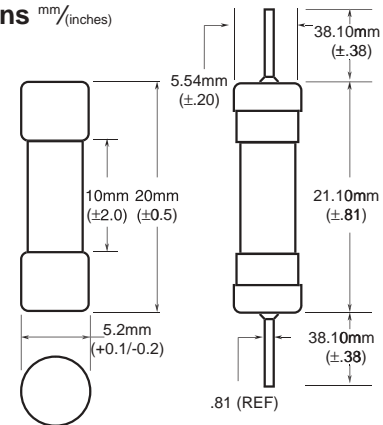

SPECIFICATIONS

Product Code	Voltage Rating AC	AC Interrupting Rating*		Typical DC Cold Resistance (ohms)**	Typical Pre-Arc I [†] t AC†	Maximum Voltage Drop (mV)‡
		250V	125V			
GMC-63mA	250V	35A	10,000A	10.350	0.0027	1400
GMC-80mA	250V	35A	10,000A	-	0.0050	1400
GMC-100mA	250V	35A	10,000A	4.775	0.0094	1200
GMC-125mA	250V	35A	10,000A	3.400	0.014	1000
GMC-150mA	250V	35A	10,000A	2.555	0.022	800
GMC-160mA	250V	35A	10,000A	2.295	0.022	730
GMC-200mA	250V	35A	10,000A	1.395	0.032	650
GMC-250mA	250V	35A	10,000A	0.965	0.046	490
GMC-300mA	250V	35A	10,000A	0.838	0.081	580
GMC-315mA	250V	35A	10,000A	0.685	0.081	480
GMC-400mA	250V	35A	10,000A	0.615	0.18	510
GMC-500mA	250V	35A	10,000A	0.335	0.41	370
GMC-600mA	250V	35A	10,000A	0.282	0.60	360
GMC-630mA	250V	35A	10,000A	0.246	0.66	360
GMC-700mA	250V	35A	10,000A	0.213	0.85	340
GMC-750mA	250V	35A	10,000A	0.213	0.85	320
GMC-800mA	250V	35A	10,000A	0.180	0.85	290
GMC-1A	250V	35A	10,000A	0.156	1.8	250
GMC-1.25A	250V	100A	10,000A	0.098	3.4	200
GMC-1.5A	250V	100A	10,000A	0.076	5.4	190
GMC-1.6A	250V	100A	10,000A	0.067	5.8	160
GMC-2A	250V	100A	10,000A	0.043	8.9	130
GMC-2.5A	250V	100A	10,000A	0.035	13	130
GMC-3A	250V	100A	10,000A	0.026	19	130
GMC-3.15A	250V	100A	10,000A	0.025	23	130
GMC-3.5A	125V	-	10,000A	0.022	25	130
GMC-4A	125V	-	10,000A	0.019	36	120
GMC-5A	125V	-	10,000A	0.014	58	120
GMC-6A	125V	-	10,000A	0.013	88	120
GMC-6.3A	125V	-	10,000A	0.012	110	120
GMC-7A	125V	-	200A	0.012	150	120
GMC-8A	125V	-	200A	0.009	200	110
GMC-10A	125V	-	200A	0.007	300	110

* Interrupting ratings: Interrupting ratings for 63mA - 6.3A were measured at 70% - 80% power factor on AC. The interrupting ratings for 7A - 10A were measured at 100% power factor on AC.

** DC Cold Resistance (Measured at <10% of rated current)

† Typical Pre-Arching I[†]t (I[†]t was measured at listed interrupting rating and rated voltage)

‡ Maximum Voltage drop (Voltage drop was measured at 20°C ambient temperature at rated current)

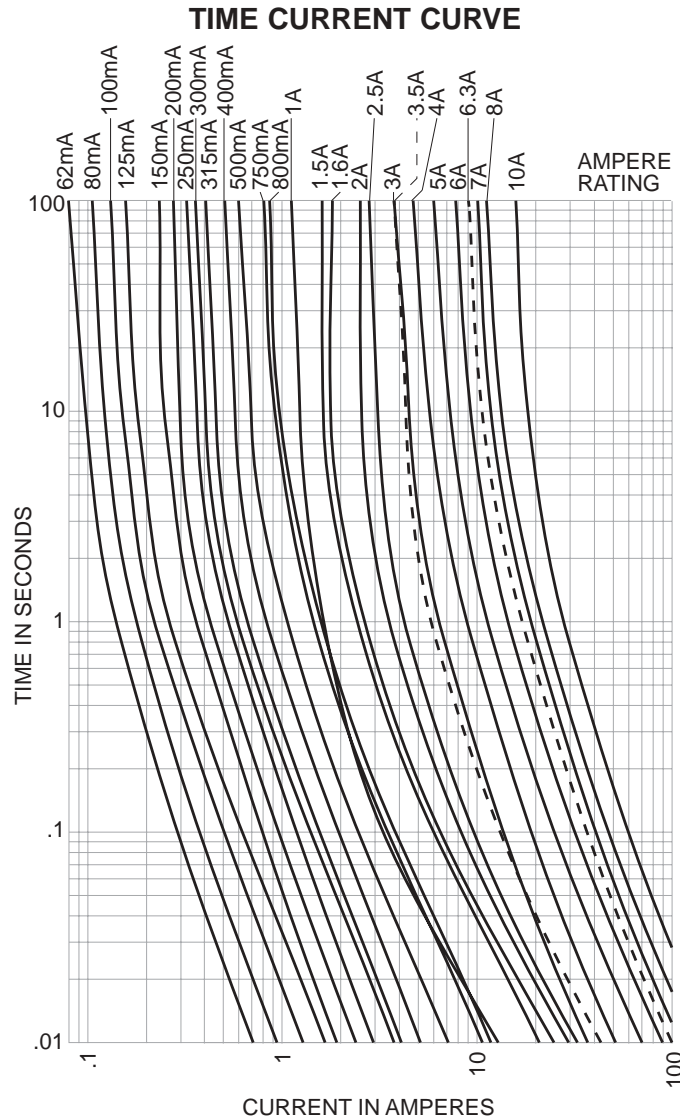

OPTION CODE	
Option Code	Description
S	Sealed with a flouropolmer sleeve to withstand aqueous cleaning
V	Axial leads - copper tinned wire with nickel plated brass overcaps

PACKAGING CODE	
Packaging Code	Description
BK	100 pieces of fuses packed into a cardboard carton with flaps folded
BK1	1,000 pieces of fuses packed into a poly bag
TR2	1,500 pieces of fuses packed into tape on a reel